

Lecture 17

(Center of Mass and Rocket Equation)

Physics 160-02 Spring 2017

Douglas Fields

Problem 8.73

8.73 • Spheres A (mass 0.020 kg), B (mass 0.030 kg), and C (mass 0.050 kg) are approaching the origin as they slide on a frictionless air table (Fig. P8.73). The initial velocities of A and B are given in the figure. All three spheres arrive at the origin at the same time and stick together. (a) What must the x - and y -components of the initial velocity of C be if all three objects are to end up moving at 0.50 m/s in the $+x$ -direction after the collision? (b) If C has the velocity found in part (a), what is the change in the kinetic energy of the system of three spheres as a result of the collision?

Figure **P8.73**

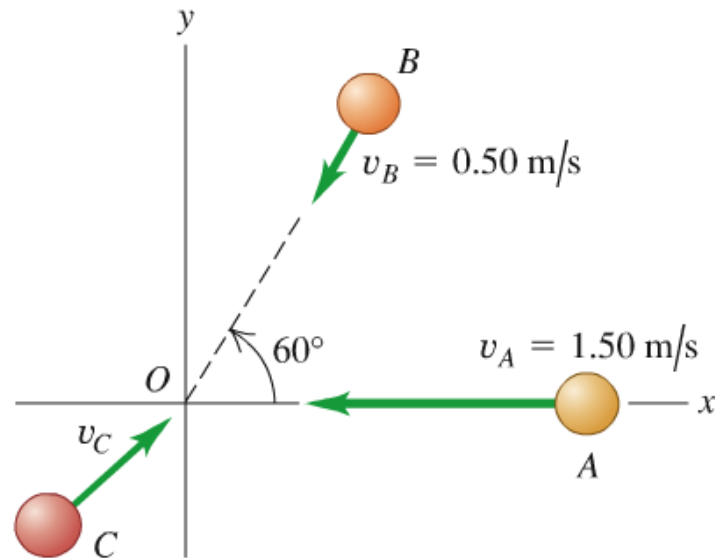

Problem 8.79

8.79 •• Combining Conservation Laws. A 5.00-kg chunk of ice is sliding at 12.0 m/s on the floor of an ice-covered valley when it collides with and sticks to another 5.00-kg chunk of ice that is initially at rest. (Fig. P8.79). Since the valley is icy, there is no friction. After the collision, how high above the valley floor will the combined chunks go?

Figure **P8.79**

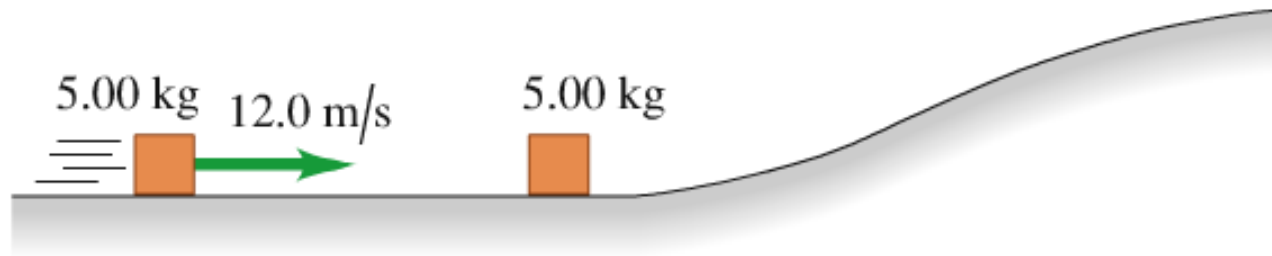

Problem 8.83

8.83 • A rifle bullet with mass 8.00 g strikes and embeds itself in a block with mass 0.992 kg that rests on a frictionless, horizontal surface and is attached to a coil spring (Fig. P8.83).

The impact compresses the spring 15.0 cm. Calibration of the spring shows that a force of 0.750 N is required to compress the spring 0.250 cm. (a) Find the magnitude of the block's velocity just after impact. (b) What was the initial speed of the bullet?

Figure **P8.83**

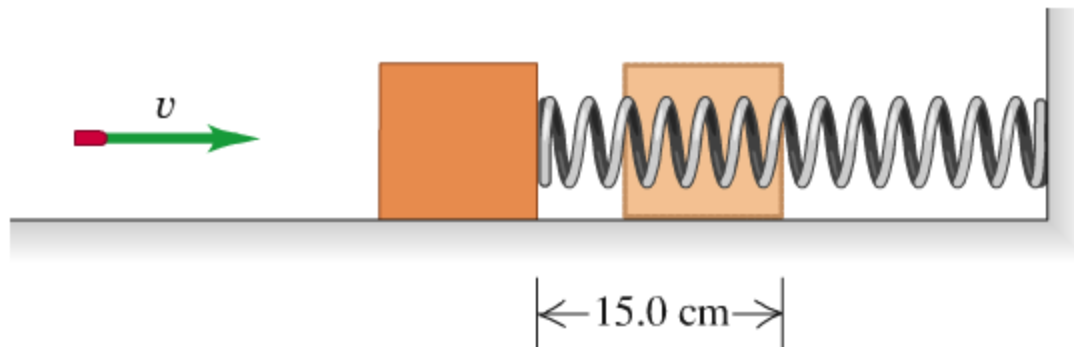

Problem 8.95

8.95 •• CP In a shipping company distribution center, an open cart of mass 50.0 kg is rolling to the left at a speed of 5.00 m/s (Fig. P8.95). You can ignore friction between the cart and the floor. A 15.0-kg package slides down a chute that is inclined at 37° from the horizontal and leaves the end of the chute with a speed of 3.00 m/s . The package lands in the cart and they roll off together. If the lower end of the chute is a vertical distance of 4.00 m above the bottom of the cart, what are (a) the speed of the package just before it lands in the cart and (b) the final speed of the cart?

Figure **P8.95**

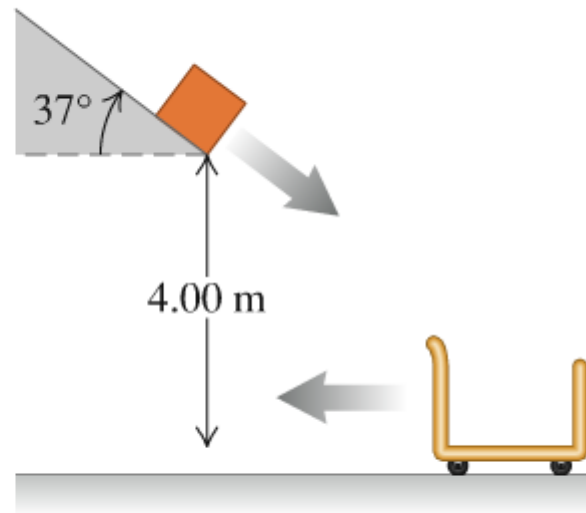

Center-of-mass

- Consider a system of masses, m_1, m_2 , etc. with locations r_1, r_2 , etc.
- Define the center of mass of this system as:

$$\vec{r}_{cm} = \frac{m_1 \vec{r}_1 + m_2 \vec{r}_2 + m_3 \vec{r}_3 + \cdots + m_n \vec{r}_n}{m_1 + m_2 + m_3 + \cdots + m_n} = \frac{\sum_i m_i \vec{r}_i}{\sum_i m_i} = \frac{1}{M} \sum_i m_i \vec{r}_i$$

- Notice that:

$$\frac{d}{dt}(\vec{r}_{cm}) = \frac{1}{M} \frac{d}{dt} \left(\sum_i m_i \vec{r}_i \right) \Rightarrow$$

$$\vec{v}_{cm} = \frac{1}{M} \sum_i m_i \vec{v}_i \Rightarrow$$

$$\vec{p}_{cm} = \sum_i \vec{p}_i$$

Center-of-mass

- Now, let's examine the motion of the center of mass (COM):

$$M\vec{r}_{cm} = \frac{M}{M} \sum_i m_i \vec{r}_i = \sum_i m_i \vec{r}_i = m_1 \vec{r}_1 + m_2 \vec{r}_2 + m_3 \vec{r}_3 + \dots \Rightarrow$$

$$\frac{d^2}{dt^2} (M\vec{r}_{cm} = m_1 \vec{r}_1 + m_2 \vec{r}_2 + m_3 \vec{r}_3 + \dots) \Rightarrow$$

$$M\vec{a}_{cm} = m_1 \vec{a}_1 + m_2 \vec{a}_2 + m_3 \vec{a}_3 + \dots \Rightarrow$$

$$M\vec{a}_{cm} = \sum \vec{F}_1 + \sum \vec{F}_2 + \sum \vec{F}_3 + \dots$$

- OK, so the motion of the COM depends upon all the forces acting on each particle. Can we simplify?

Center-of-mass

- Let's categorize all the forces into either external forces (something acting from outside the system), or internal forces (particles within the system acting on each other).

$$\begin{aligned} M\vec{a}_{cm} &= \sum \vec{F}_1 + \sum \vec{F}_2 + \sum \vec{F}_3 + \dots \\ &= \sum \vec{F}_{int} + \sum \vec{F}_{ext} \end{aligned}$$

- But, from Newton's 3rd Law, we know that if one particle pushes on another, the other pushes back with a force of equal magnitude, but opposite in direction, so the sum of the internal forces is zero (it's just a sum of pairs of forces that each cancel), so

$$M\vec{a}_{cm} = \sum \vec{F}_{ext}$$

Center of Mass

- If there is no NET external forces, then the COM moves with a constant velocity.
- If there are external forces (say, gravity), then the COM moves according to the equations of motion with that acceleration.

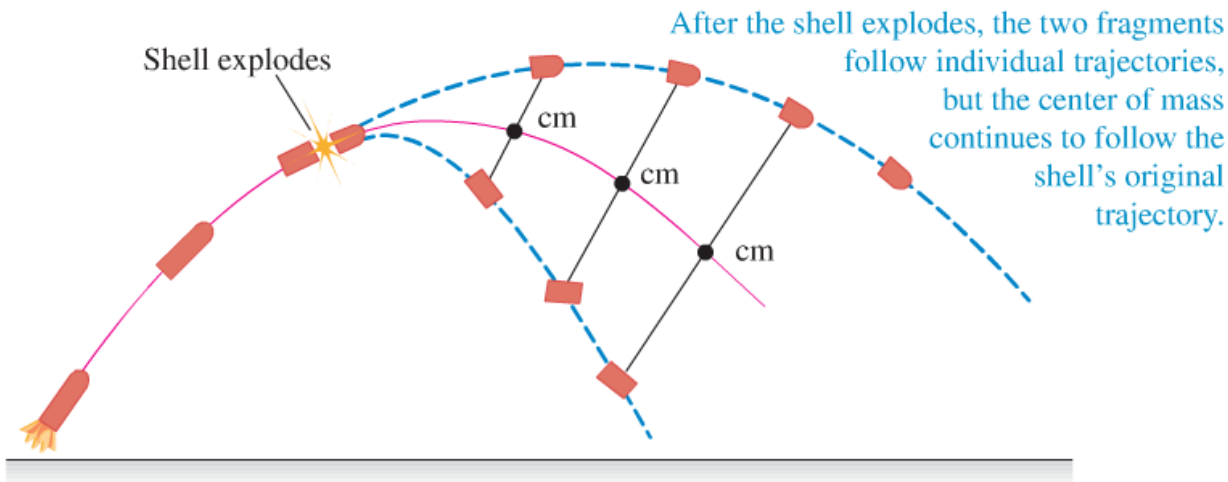

CPS Question 21-1

- **Two physics students play tug-of-war on a frictionless surface. How does their center of mass change if the heavier student is pulling harder?**

A) It moves toward the heavier student.

B) It doesn't change.

C) It moves toward the lighter student.

D) Not enough information to solve.

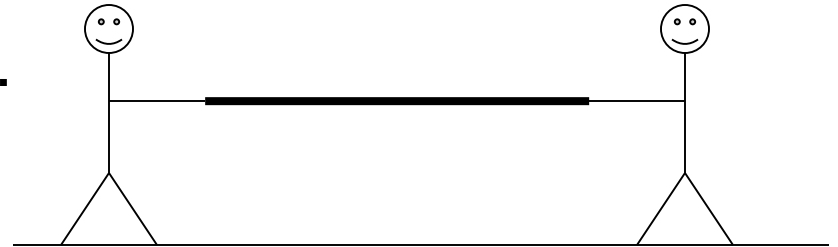

Problem 8.54

8.54 • A 1200-kg station wagon is moving along a straight highway at 12.0 m/s. Another car, with mass 1800 kg and speed 20.0 m/s, has its center of mass 40.0 m ahead of the center of mass of the station wagon (Fig. E8.54). (a) Find the position of the center of mass of the system consisting of the two automobiles. (b) Find the magnitude of the total momentum of the system from the given data. (c) Find the speed of the center of mass of the system. (d) Find the total momentum of the system, using the speed of the center of mass. Compare your result with that of part (b).

Figure **E8.54**

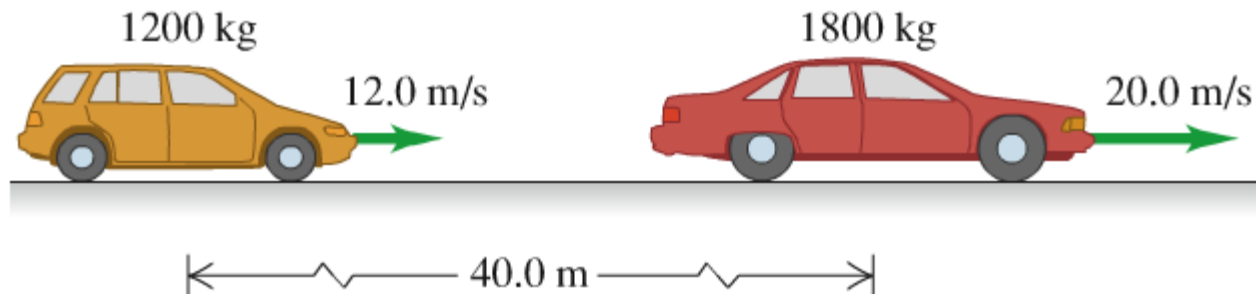

Problem 8.100

8.100. A 45.0-kg woman stands up in a 60.0-kg canoe 5.00 m long. She walks from a point 1.00 m from one end to a point 1.00 m from the other end (Fig. 8.48). If you ignore resistance to motion of the canoe in the water, how far does the canoe move during this process?

Figure 8.48 Problem 8.100.

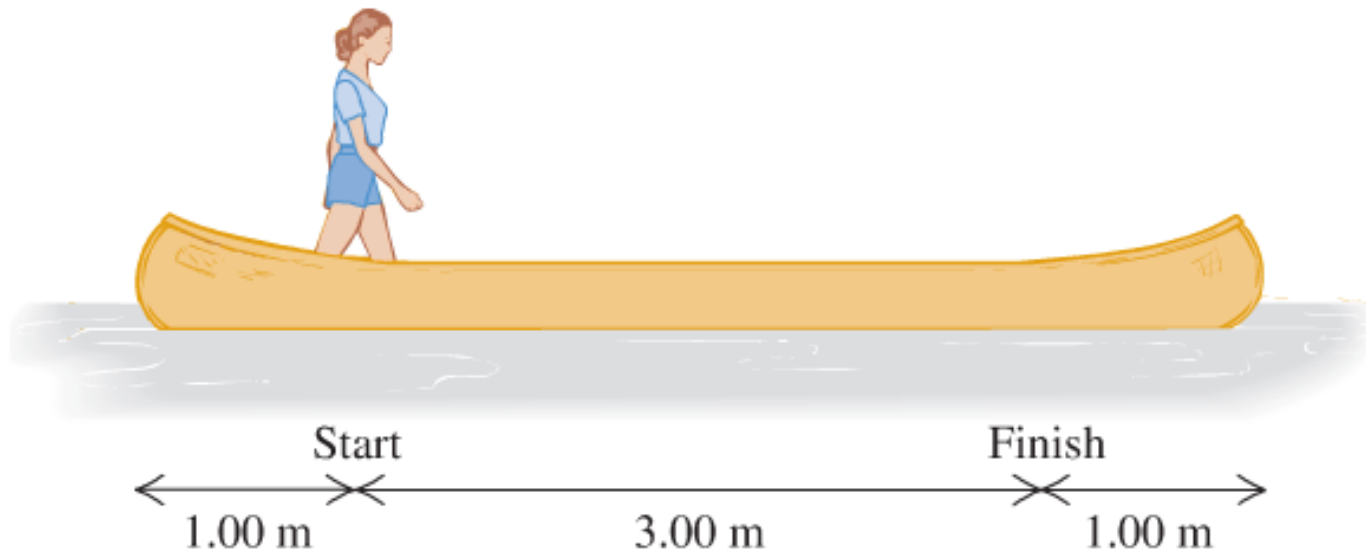

Rocket Equation

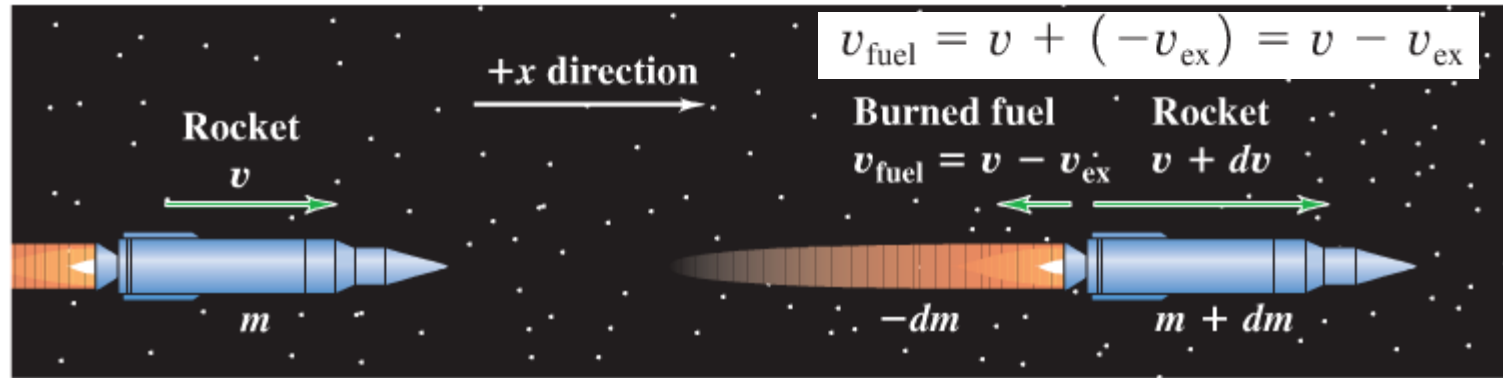

dm is -

$$mv$$

$$(-dm)v_{\text{fuel}} = (-dm)(v - v_{\text{ex}})$$

$$(m + dm)(v + dv)$$

$$(m + dm)(v + dv) + (-dm)(v - v_{\text{ex}})$$

$$mv = (m + dm)(v + dv) + (-dm)(v - v_{\text{ex}})$$

$$m dv = -dm v_{\text{ex}} - dm dv$$

$$m \frac{dv}{dt} = -v_{\text{ex}} \frac{dm}{dt} \rightarrow F = -v_{\text{ex}} \frac{dm}{dt} \quad \text{Thrust!}$$